

# SafeLine<sup>ANTEC</sup>

## Horizontal system

Installation guide for the "SafeLine" type anchorage device

Tested in compliance with EN 795: 1996

No.: SE-...



Version: 09.10.2008

SE 67

Subject to technical alterations!



### Contents

1. General information
  - 1.1 Our objective
2. Technical documents
  - 2.1 Product description
  - 2.2 Quality and guarantee of components
  - 2.3 Description of components
    - 2.3.1 Standard components
    - 2.3.2 Optional components
3. Installation
  - 3.1 General information
    - 3.1.1 Project planning
    - 3.1.2 On-site installation
    - 3.1.3 Acceptance tests after installation
  - 3.2 Installation instructions
    - 3.2.1 Overview of installation
    - 3.2.2 Installing posts and end plates
    - 3.2.3 Installing the intermediate bracket
    - 3.2.4 Installing the curved section
    - 3.2.5 Installing the energy absorber
    - 3.2.6 Installing the tensioner/pre-tension indicator
    - 3.2.7 Installing the rope
    - 3.2.8 Identification plate

This manual is protected by copyright!

Duplicating and circulating this manual is not permitted without written consent of the author as per §§16, 17 German Copyright Act, and Sperian Fall Protection Deutschland GmbH & Co. KG reserves the right to prosecute as per § 106 German Copyright Act in case of any violation.

**In this version changed:** Logo

### **General instructions**

Follow the instructions given in the application and maintenance manual SE 66 implicitly.

FEPAKO  
VISITA NUESTRA TIENDA  
EN [FEPAKO.COM](http://FEPAKO.COM)

### 1. General information

Thankyou for choosing the SafeLine anchorage device. Please follow the instructions given in this installation guide (SE 67), the application and maintenance manual (SE 66) as well as prevailing accident prevention and safety regulations so that you will be totally satisfied with this product.

The SafeLine anchoring device meets the requirements of the Standard EN 795, Class C.

The Notified Body

EXAM BBG Prüf- und Zertifizier GmbH  
Dinnendahlstraße 9  
44809 Bochum, CE 0158

has tested all standard parts of the cable guide based on a type examination test according to the Standard EN 795, Class C.

The SafeLine anchorage device can be mounted on different bases like concrete, masonry, steel or wood. We offer a variety of optional fixing components (pls. Refer to section 2.3.2).

Before installation, ensure that the structure on which the SafeLine anchorage device is to be fixed can withstand the stresses resulting from a fall, a certificate for stability, from a qualified engineer.

If the load-bearing capacity of the base cannot be certified by way of calculation, it must be determined by conducting tests. Adhere to the Installation recommendations compliant to EN 795 standard for this purpose.

Sperian Fall Protection Deutschland GmbH & Co. KG does not assume any guarantee for the installation of the anchorage device as well as for additional brackets and anchorage points supplied and installed by the installing company and that come under the responsibility of the installing company.

FEPAKO  
VISITA NUESTRA TIENDA  
EN FEPAKO.COM

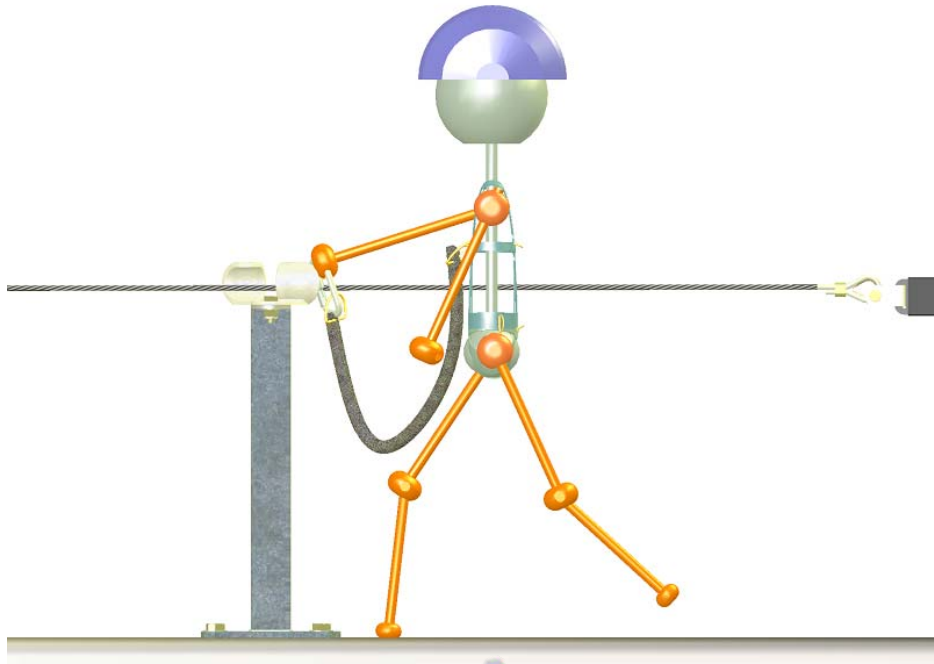

### 1.1 Our objective

To develop an anchorage device having the following properties and that fulfil the expectations of installers and users:

Quick generation of a parts list for offers and installation

⇒ SafeLine software generates an accurate parts list for the components to be installed based on the input data of the assembler.

System comprising a limited number of components

⇒ Rope tensioner, absorber, intermediate element, curved section, steel rope, wire rope clamps, thimble, identification plate, posts

Quick and easy installation

⇒ Pre-tension display and installation without a special tool

Simple application for three persons

⇒ Direct connection of the anchorage device to the karabiners

Attractively and ergonomically designed anchorage device

## 2. Technical documents

### 2.1 Product description

The SafeLine anchorage device fulfils the requirements of EN 795 Class C. It secures up to three persons against falls from height and simultaneously provides them with complete freedom of movement. The rope guide can be designed as straight or with 90° curves. The distance between two SafeLine intermediate brackets should be between 2 m and 15 m. The energy absorber mounted at the end of the cable allows absorption of rope forces via “energy dissipation”. A karabiner is used for connecting a user to the cable. This karabiner must be guided over the intermediate bracket and curved sections manually.

### 2.2 Quality and guarantee of components

The components of the SafeLine anchorage device are manufactured in conformity with ISO 9001. Special care has been taken in all manufacturing stages. Suitably marked components ensure complete traceability of the SafeLine system.

All parts are manufactured using stainless or hot-dip galvanized steel. Under normal operating conditions, Sperian Fall Protection Deutschland GmbH & Co. KG assures a guarantee of 2 years for all manufacturing defects (an exceptionally corrosive environment may reduce this limit).

FEPAKO  
VISITA NUESTRA TIENDA  
EN [FEPAKO.COM](http://FEPAKO.COM)



### 2.3 Description of components

#### 2.3.1 Standard components

Product no. 1012650, order no. 24441

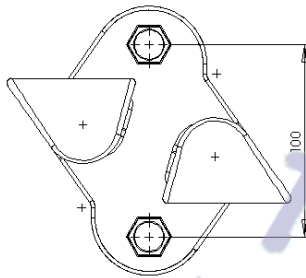
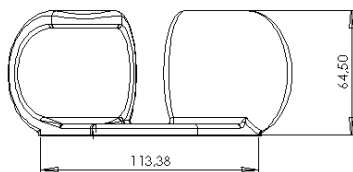

#### **Intermediate bracket**

The intermediate bracket made of stainless steel 316 allows a user to move safely without needing to disconnect from the anchorage device. The maximum distance between two intermediate brackets can be 15 m. The intermediate bracket can be fixed on the free upright posts (product no. 1009731/1013573), on vertical or horizontal concrete surfaces.

**Note:** Overhead installation is not permitted!

**Material:** Stainless steel 316L

#### **Fastening:**

2x M12 A2-70 screws (included in the scope of supply), required tightening torque = 60 Nm;  
2x M12 PAL locknuts

**Net weight:** 1.05 kg

Product no. 1012671, order no. 24299

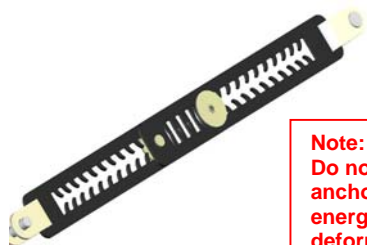
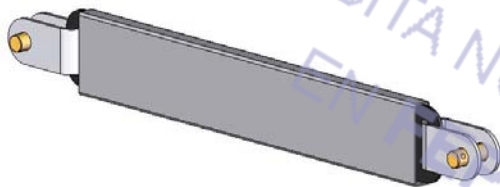

**Note:**  
Do not use the SafeLine anchorage device if the energy absorber has deformed due to overload.

#### **Energy absorber**

The energy absorber has been developed for dissipating the energy that works on the end anchor due to stresses resulting from a fall. The absorber limits induced force to 8 kN in the anchorage depending on the length of the anchorage device (2 m to a maximum of 200 m). Since the absorber is intended only for a one-time use, the fall indicator is released in case of a fall. The absorber must then be replaced and the general condition of the anchorage device must be checked.

**Material:** Stainless steel 316L, PVC

#### **Absorber element:**

Maximum displacement: 250 mm  
Threshold limit: 8.0 kN

**Net weight:** 0.9 kg

**Product no. 1012673, order no. 24548**

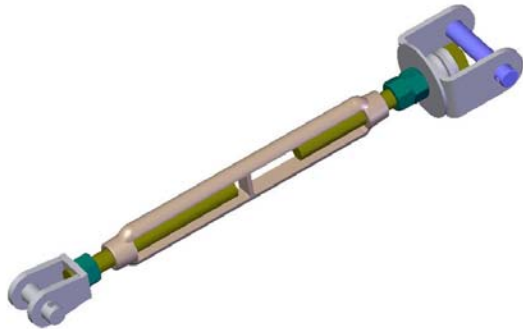

### **Tensioner/pre-tension indicator**

The tensioner/pre-tension indicator can be used for tightening the cable. The built-in blue disc can be used for checking the correct pre-tension of the system (0.8 kN).

Correct pre-tension of the cable ensures correct functioning of all system components in case of a fall.

Material: Stainless steel 316L

Dimensions:  
Lengths 335 mm to 470 mm

Net weight: 0.86 kg

**Product no. 90009347, order no. 24446**



### **Stainless steel wire cable**

A wire cable is used for the SafeLine anchorage device.

The maximum span between two intermediate brackets is 15 m.

Material: Stainless steel 316L

Assembly:  
Diameter 8 mm  
7x19 wires crossed towards right, pre-formed  
Diameter of wires: 0.63 mm  
Metallic core  
Cross section: 41.5 mm<sup>2</sup>

Net weight: 0.26 kg/m

**Product no. 90009348, order no. 24483**



### **Sleeved thimble loop**

Sleeved thimble loop can be ordered in combination with the wire cable (product no. 90009347). The thimble is manufactured in the factory using a press sleeve. It is used for connecting the rope with the energy absorber.

Material: Copper, stainless steel 316



**Product no. 1009509, order no. 24524**



### Cable end connectors for on-site installation

For connecting another cable end to the rope tensioner. Comprises one thimble and four wire cable clamps.

Material: Stainless steel 316

Net weight: 0.2 kg

**Product no. 1013910, order no. 24534**

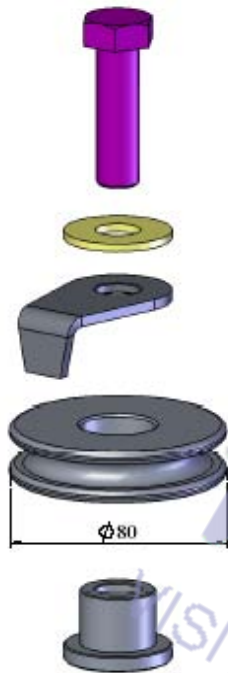

### Curved section

The curved section enables installing 90° curves of the SafeLine cable. The maximum span between two intermediate or end structural anchors is 15 m. Installation on curve post, product no. 1014320 or on a suitable corbel.

The karabiner must be removed from the anchorage device while crossing over the curved section. Use of a twin-tail lanyard with energy absorber is recommended..

Material: Stainless steel 316, aluminium

### Fastening:

1x M16 A4 screw (included in the scope of supply), required tightening torque = 60 Nm

Net weight: 0.42 kg

**Order no. 24564**

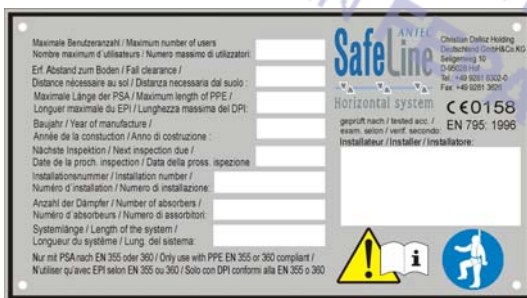

### Identification plate

Material: Aluminium, thickness 1 mm

### Languages:

German, English, French, Italian

Net weight: 0.06 kg

### 2.3.2 Optional components

**Product no. 1009720, order no. 24546**

**Product no. 1013576, order no. 24442**

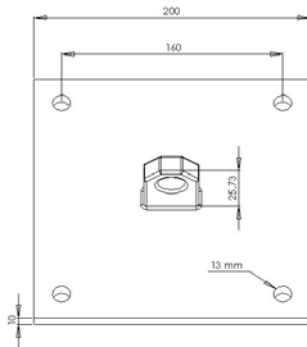
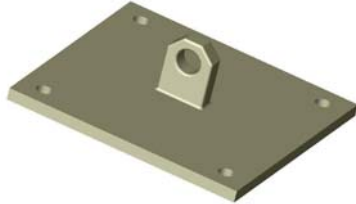

**order no. 24490**

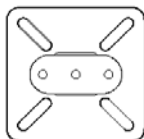
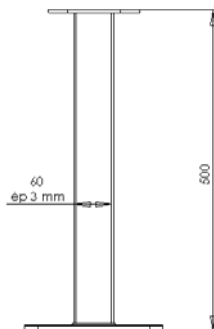

End plate, stainless steel/steel

For installing the anchorage device on walls or ground. The energy absorber or the tensioner/pre-tension indicator can be attached directly to the end plate.

Material:

Product no. 1009720: Stainless steel 316L, electro-polished

Product no. 1013576: Steel, hot-dip galvanized

Dimensions:

L/B/T = 200/200/10 mm

Fastening:

4x M12-A4 screws (not included in the scope of supply)

Net weight: 3.3 kg

Standard post, stainless steel

The standard post has been designed for loads induced by SafeLine end- and intermediate anchors. It can be installed on concrete-, metal- and wooden bases depending on the permissible peak load of the base.

SafeLine intermediate brackets (product no. 1012650) and SafeLine end adapters (product no. 1010015) can be installed on the standard post.

Material: Stainless steel 304

Dimensions:

Base plate: L/B/T = 210/221/10 mm

Total height: 400 mm

Fastening:

4xM12-A4 screws (not included in the scope of supply) or optionally available counter plate, product no. 1009732

Centre distance between fixing screws: 80 to 160 mm

Net weight: 6 kg

**Product no. 1010015, order no. 24489**  
**Product no. 1013575, order no. 24445**

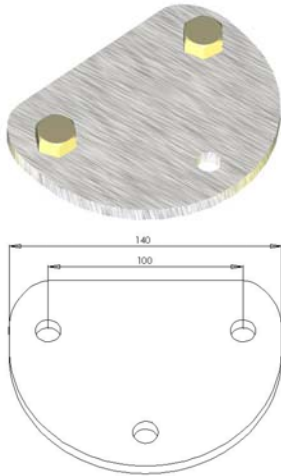

End adapter, stainless steel/steel

For installing the anchorage device on a standard post (product no. 1009731/1013573).  
 The energy absorber or the tensioner/pre-tension indicator can be attached directly to the end adapter.

Material:

Product no. 1010015: Stainless steel 304  
 Product no. 1013575: Steel, hot-dip galvanized

Fastening:

2xM12, A4-70 screws (included in the scope of supply)

Net weight: 1.1 kg

**Product no. 1009744, order no. 24568**  
**Product no. 1013572, order no. 24444**

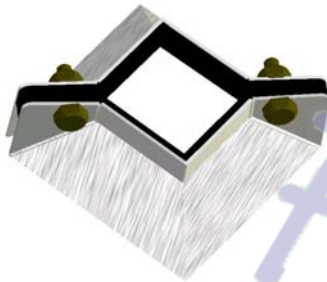

Detachable collar

For sealing the standard post (product no. 1009731 / 1013573)

Material:

Product no. 1009744: Stainless steel 304  
 Product no. 1013572: Steel, hot-dip galvanized

Fastening:

2xM5, A4-70 screws (included in the scope of supply)

Net weight: 0.36 kg

**Product no. 1009732, order no. 24547**  
**Product no. 1013571, order no. 24499**

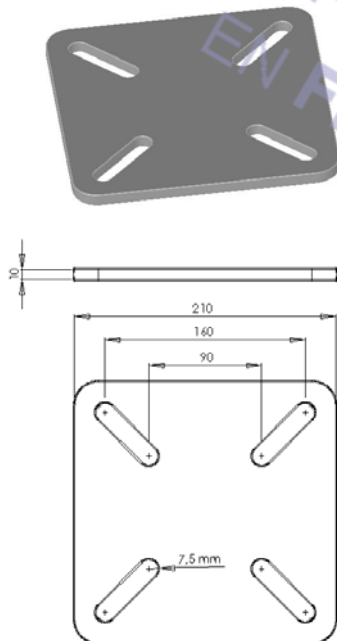

Counter plate, stainless steel/steel

The counter plate can be used for clamping the standard posts or curved posts on a steel beam.

Material:

Product no. 1009732: Stainless steel 304  
 Product no. 1013571: Steel, hot-dip galvanized

Fastening:

4xM12, A4-70 screws (not included in the scope of supply)

Net weight: 3.0 kg

order no. 24443

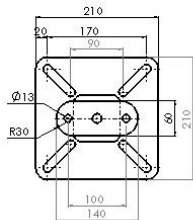
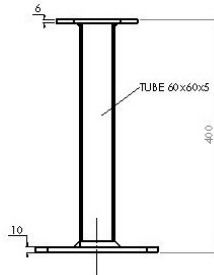

### Standard post, hot-dip galvanized steel

The standard post has been designed for loads induced by SafeLine end- and intermediate anchors. It can be installed on concrete-, metal- and wooden bases depending on the permissible peak load of the base. SafeLine intermediate brackets (product no. 1012650) and SafeLine end adapters (product no. 1010015) can be installed on the standard post.

Material: Steel, hot-dip galvanized

### Dimensions:

Base plate: L/B/T = 210/210/10 mm

Total height: 400 mm

### Fastening:

4x M12-A4 screws (not included in the scope of supply) or optionally available counter plate, product no. 1009732

Centre distance between fixing screws: 90 to 170 mm

Net weight: 6,8 kg

Product no. 1014320, order no. 24567

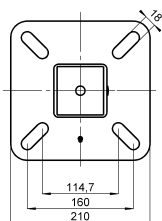
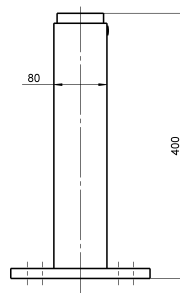

### Curved post, hot-dip galvanized steel

The curved post has been designed for loads induced by the SafeLine curved section. It can be installed on concrete-, metal- and wooden bases depending on the permissible peak load of the base. The SafeLine curved section (product no. 1013910) can be installed on the curved post.

Material: Steel, hot-dip galvanized

### Dimensions:

Base plate: L/B/T = 210/210/15 mm

Total height: 400 mm

### Fastening:

4x M12-A4 screws (not included in the scope of supply) or optionally available counter plate, product no. 1009732

Centre distance between fixing screws: 115 to 160 mm

Net weight: 9,85 kg

### 3. Installation

#### 3.1 General information

##### 3.1.1 Project planning

Project planning must be done before installation. Inspecting the installation site and determining tolerances as well as preparing precise drawings are recommended. This project planning enables determination of fastening types that can be derived from the following technical elements: quality of bases, possible distance between intermediate brackets, and the number of users of the anchorage device. In addition, check whether the minimum required distance from the ground has been ensured. The SafeLine calculation program can be used for these calculations. This project planning must consider calculations determined as per EN 795 Class C.

##### 3.1.2 On-site installation

Adhere to the prevailing accident prevention and safety regulations of the respective country while installing. Follow the installation recommendations of EN795 standard and generally accepted technical standards. It is recommended that the installer and the customer should have a coordinated installation planning based on the results of installation site inspection.

##### 3.1.3 Acceptance tests after installation

After installation, the installer and customer or the person in-charge must conduct functional and acceptance test and maintain a log for them.

Especially check whether

- the tightening torques of screw joints have been adhered to (refer to the description of components)
- the karabiner can be glided smoothly through intermediate brackets
- all information has been provided on the identification plate.

FEPAKO  
VISITA NUESTRA TIENDA  
EN [FEPAKO.COM](http://FEPAKO.COM)

### 3.2 Installation instructions

#### 3.2.1 Overview of installation

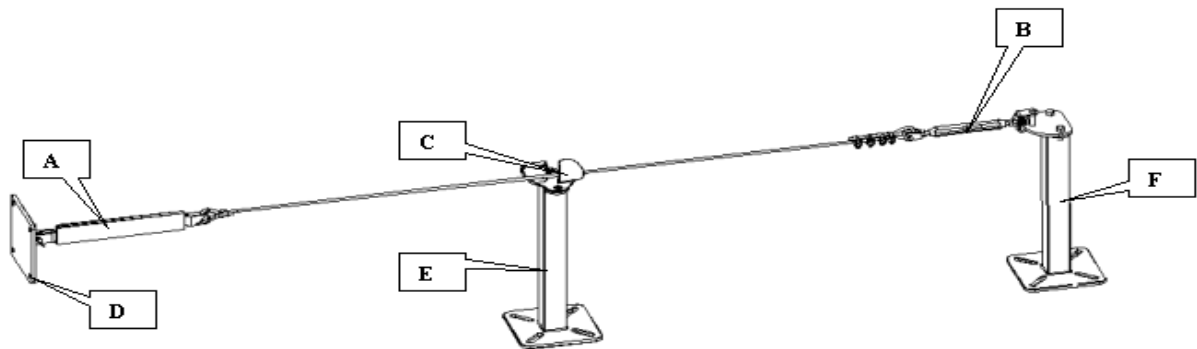

- A: Energy absorber
- B: Tensioner/pre-tension indicator
- C: Intermediate bracket
- D: End plate
- E: Intermediate post
- F: End post

**Image 3.1: Installation of a straight anchorage device**

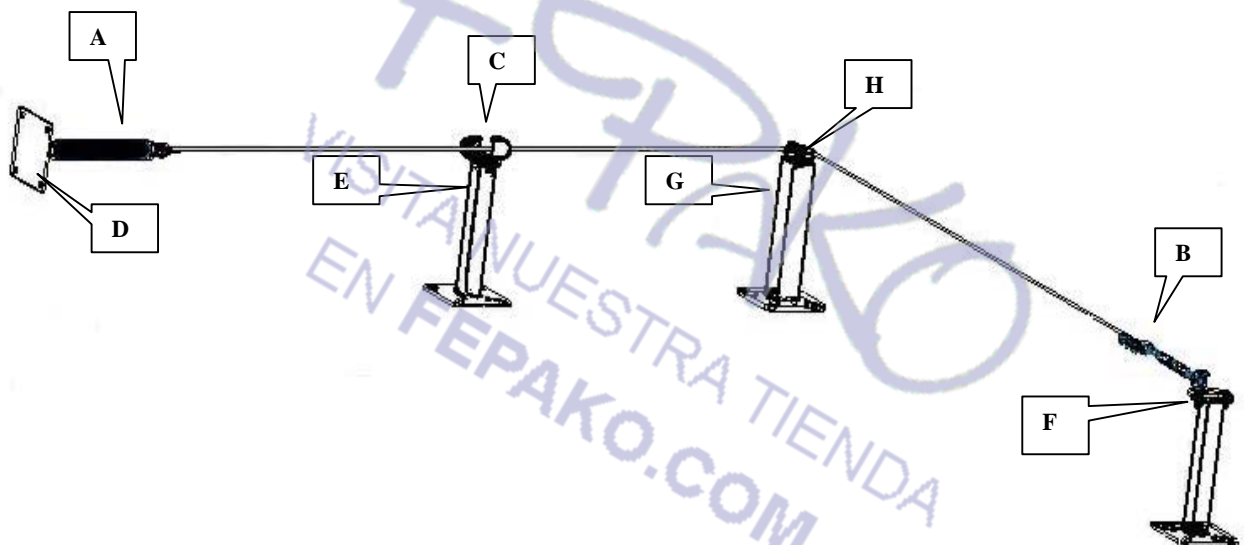

- A: Energy absorber
- B: Tensioner/pre-tension indicator
- C: Intermediate bracket
- D: End plate
- E: Intermediate post
- F: End post
- G: Curved post
- H: Curved section

**Image 3.2: Installation of an anchorage device with a 90° curve**



### 3.2.2 Installing posts and end plates

Image 3.3 shows the installation principle with an end post, intermediate post and an end plate. Position the post with a maximum cable span of 15 metres. Align the intermediate posts in the cable line to ensure smooth crossover of the intermediate bracket.

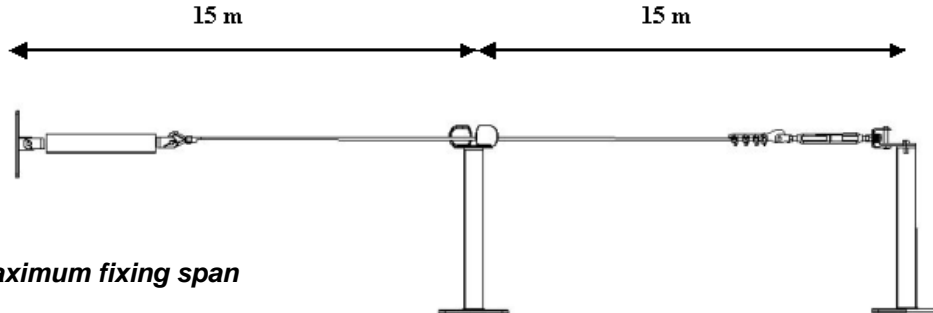

**Image 3.3: Maximum fixing span**

### Installation on a steel beam

Use M12 connectors with the minimum A4-70 grade for installing on steel beams. Installation can be done by clamping (in combination with the counter plate, product no. 1009732/1013571) or direct bolting. In case of clamping, align M12 connectors in the elongated hole such that they are as close as possible to the flange of the steel beam. (Refer to image 3.4)

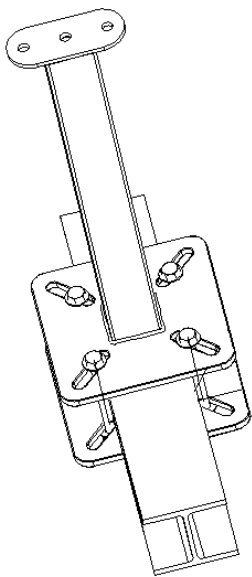

**Image 3.4: Clamping on a steel beam**

### Installation on a reinforced concrete base

For fixing the stands and end plates, only use fixings that are specifically designed for reinforced concrete construction. The minimum concrete quality, minimum component thickness and the required edge distances depend on the manufacturers specification for the fixings used. Insert the fixings in accordance with the setting instructions of the manufacturer. Insert the dowel pins at the end of elongated holes of the sole plate. (Refer to image 3.5)

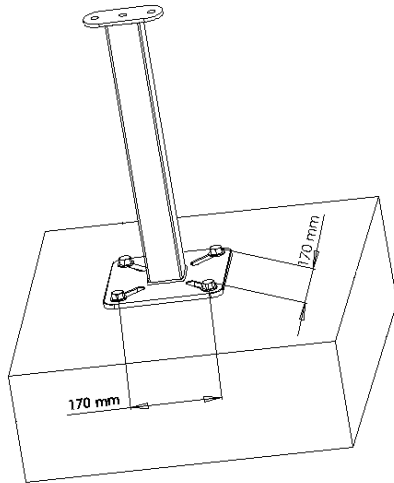
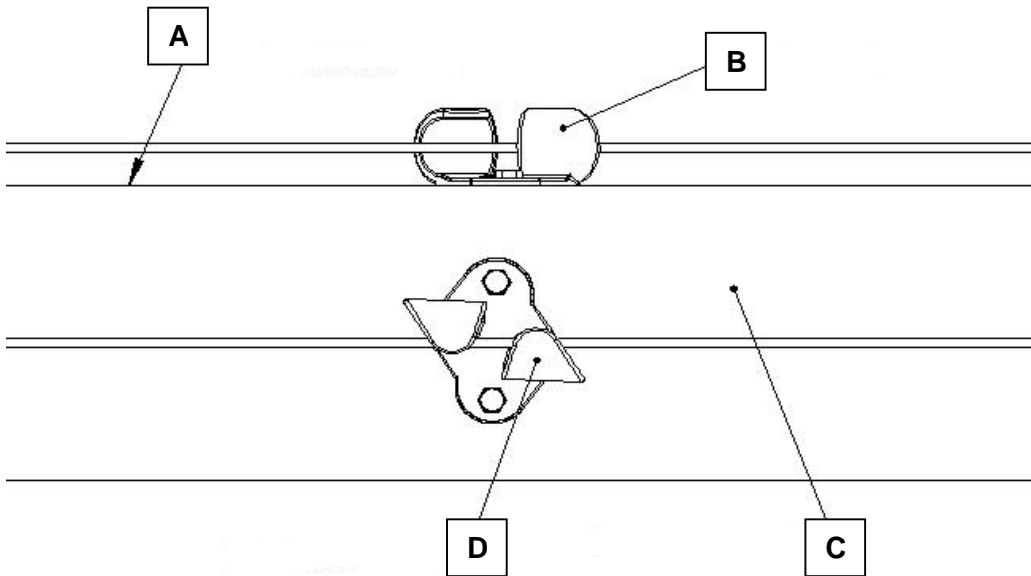

**Image 3.5: Installation on reinforced concrete**

FEPAKO  
VISITA NUESTRA TIENDA  
EN [FEPAKO.COM](http://FEPAKO.COM)

### 3.2.3 Installing the intermediate bracket

The intermediate bracket can be fixed on a post, a wall or ground. Installing it directly to a roof is not permitted.



C: Installation on wall

D: Vertical intermediate bracket

**Image 3.6: Installing the intermediate bracket**

#### Installation on a post

For installing on a post, align the holes in line with those in the top plate of the post and fix using the supplied M12 A2-70 screws (required tightening torque = 60 Nm). Secure the screw joint with the supplied M12 PAL nut.

#### Installation on a reinforced concrete base

For fixing the stands and end plates, only use fixings that are specifically designed for reinforced concrete construction. The minimum concrete quality, minimum component thickness and the required edge distances depend on the manufacturers specification for the fixings used. Insert the fixings in accordance with the setting instructions of the manufacturer.

### 3.2.4 Installing the curved section

Installation can be done on the curved post (product no. 1014320) or another substructure dimensioned for the load.

The curved section is fixed using a M16 screw (required tightening torque = 60 Nm). Refer to image 3.7 for the installation sequence of components. Ensure that the shackle (part C) lies on the outer side of the curve and the cable is enclosed by the shackle (part C) (refer to image 3.8).

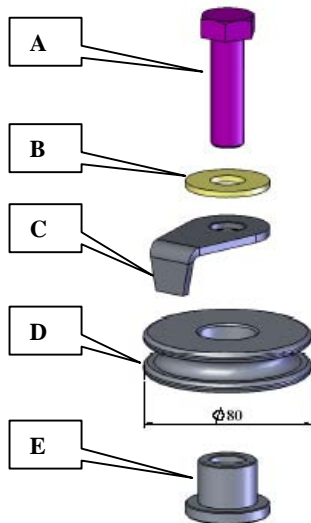

- A: M16 screw
- B: Washer
- C: Shackle
- D: Pulley
- E: Bearing

**Image 3.7: Installation sequence of the curved section**

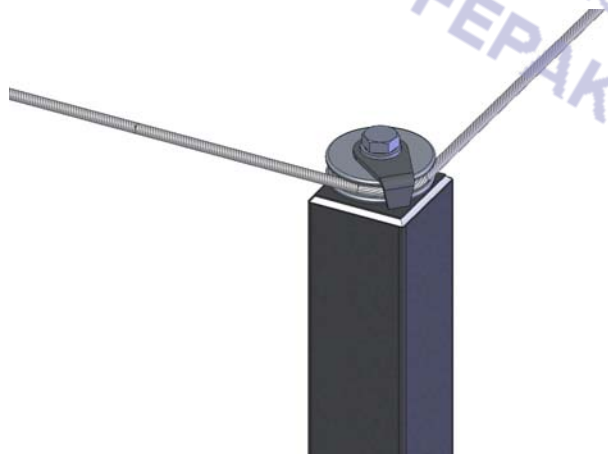

**Image 3.8: Installing the curved section on the curved post**

A maximum of three curved sections should be mounted on an anchorage device. In case of systems with one curve, one energy absorber per end anchor is recommended for installation. In case of systems with two or three curved sections, one energy absorber per end anchor is required for installation. Use the connector (order no. 24592) (refer to image 3.9) for connecting the cable tensioner and the energy absorber.

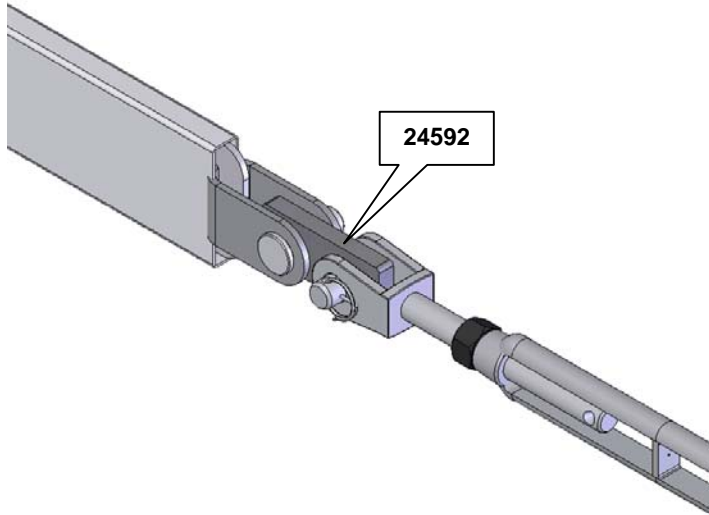

**Image 3.9: Connecting the cable tensioner and the energy absorber**

FEPAKO  
VISITA NUESTRA TIENDA  
EN [FEPAKO.COM](http://FEPAKO.COM)

### 3.2.5 Installing the energy absorber

The SafeLine anchorage device must mandatorily contain an energy absorber in order to ensure the safety of the system.

The energy absorber must be installed before the cable and the tensioner/pre-tension indicator. In order to install it, pull the safety cotter pin from the axis of one of the two sides of the energy absorber, pull the axis, align the fork of the energy absorber with the end piece, then push the axis again and secure using the safety cotter pin. (Refer to images 3.10 and 3.11).



**Image 3.10: Installing the energy absorber pin**

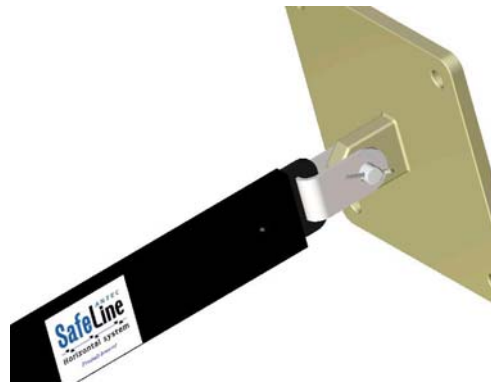
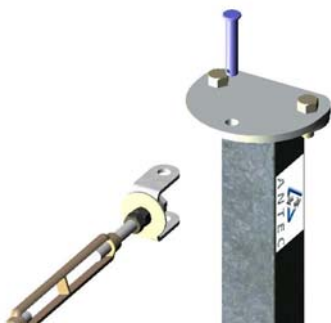

**Image 3.11: Checking the safety cotter pin**

### 3.2.6 Installing the tensioner/pre-tension indicator

Pull the safety cotter pin from the axis towards the side of the pre-tension indicator and remove. Align the fork of the tensioner with the end piece and then push the axis again and secure using the cotter pin (image 3.12).

Before installing the cable, open the tensioner by rotating the tensioning body in order to obtain the maximum tensioning path. Ensure that the thread projection is adequate (refer to image 3.13). We recommend lubricating the threads with an anti-friction coat (MoS<sub>2</sub> anti-friction lacquer) before tensioning the cable.



**Image 3.12: Installing the tensioner rope**

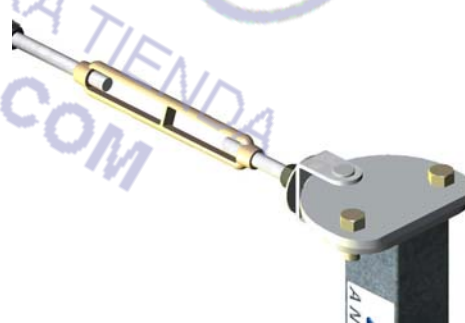

**Image 3.13: Adjustment before installing the**



### 3.2.7 Installing the cable

#### Installing the cable on the energy absorber

Remove the safety cotter pin from the axis of the energy absorber and pull out the axis. Slide the sleeved thimble loop in the fork of the absorber, push the axis again and secure using the safety cotter pin.

#### Installing the rope of the tensioner/pre-tension indicator

Unwind the cable in the direction of the tensioner. Feed the cable over the intermediate bracket gradually and ensure that the cable accurately feed over the intermediate bracket. If a curve has been installed in the system, the cable must be enclosed by the shackle (refer to image 3.8).

Pre-tighten the cable manually. We recommend using a tensioning device in case of long lengths. Ensure that the force during the tensioning process is not greater than 7 kN, otherwise the energy absorber may be damaged. If the absorber is damaged, the installer is under obligation to replace it.

Attach the 4 cable clamps and one thimble (product no. 1009509) for creating a loop on the tensioner side. Refer to images 3.11 to 3.13. The distance between each cable clamp should be 6 to 8-times the cable diameter (50 to 60 mm).

Note! Always ensure that the non-free end of the cable is placed against the clamp shoe and the free end of the cable is placed under the bow. Tighten M6 nuts of cable clamps using a tightening torque of 6 Nm.



**Image 3.14 – 3.16: On-site installation of the rope end joint using wire cable clamps**

#### Tensioning the cable

Rotate the body of the tensioner anticlockwise. The correct pre-tension of 0.8 kN is attained when the pre-tension disc can be rotated freely. Then lock the threads using a locknut.

### 3.2.8 Identification plate

Affix the identification plate containing all EN795 standard-compliant identification information at the access points. The installer must additionally fill in the site-specific information using a permanently legible font:

- The name of his company
- The maximum number of users who can secure themselves simultaneously
- Required distance from the ground
- Year of manufacture
- Next inspection
- Installation number of the installer
- Number of energy absorbers
- Length of the system

FEPAKO  
VISITA NUESTRA TIENDA  
EN [FEPAKO.COM](http://FEPAKO.COM)